

ASSEMBLY INSTRUCTIONS FOR THE FORCE Z-23

FINE FINISH BROOM



ABI Attachments, Inc – 520 S. Byrkit Ave, Mishawaka, Indiana 46544

(877) 788-7253

PARTS INCLUDED



- ① BRISTLE SECTIONS
- ② BROOM FRAME
- ③ ATTACHMENT BRACKETS
- ④ TOPLINK BRACKETS
- ⑤ TOPLINK

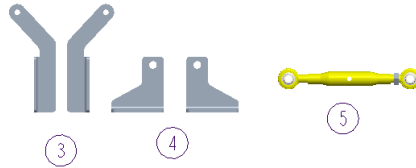

HARDWARE INCLUDED

- (2) 1/4-20 BOLTS
- (8) 3/8-16 BOLTS
- (1) 5/8-11 BOLT
- (1) 5/8-11 NUT
- (2) 1/4 LOCKWASHERS
- (8) 3/8 LOCKWASHERS
- (2) 1/4 WASHERS
- (8) 3/8 WASHERS
- (2) 5/8 WASHERS

TOOLS NEEDED

- 7/16 WRENCH OR SOCKET
- 9/16 WRENCH OR SOCKET
- 15/16 WRENCH AND SOCKET (OR TWO WRENCHES)



NOTE: KEEP ALL HANDS AND FEET CLEAR DURING USE.



NOTE: REFER TO THE DOCUMENTATION INCLUDED WITH YOUR ABI Z-23 FORCE FOR PROPER USE, ATTACHMENT INSTRUCTIONS, AND SAFETY PERCAUTIONS!



CAUTION: AN IMPROPERLY COUPLED TOOL CAN RESULT IN DAMAGE OR SERIOUS INJURY.

- 1) Unbox your fine finish broom and ensure you have all the parts on the list included. Locate the front and back edge of the main broom frame: the back of the frame has 4 holes drilled into it for attaching flat brackets, whereas the front of the frame has none.

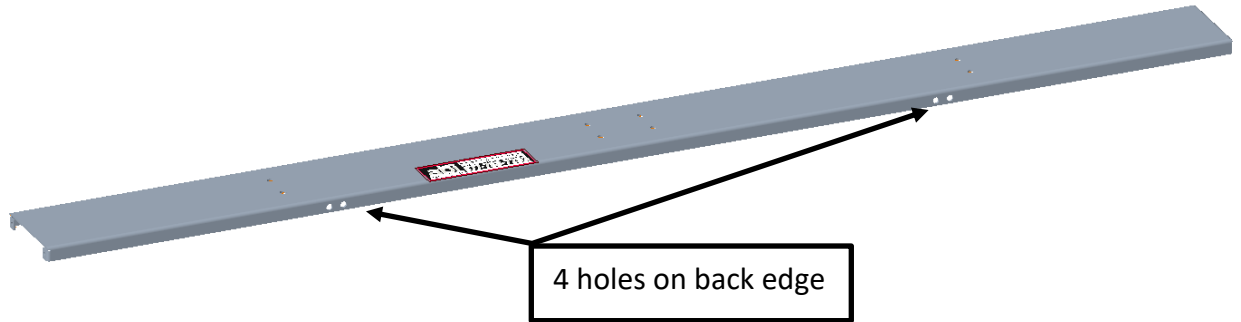

- 2) On the broom frame, locate the end cap with loosened hardware (nut and washers). Remove the hardware and end cap with a wrench (or your fingers) and set aside. [fig. A]

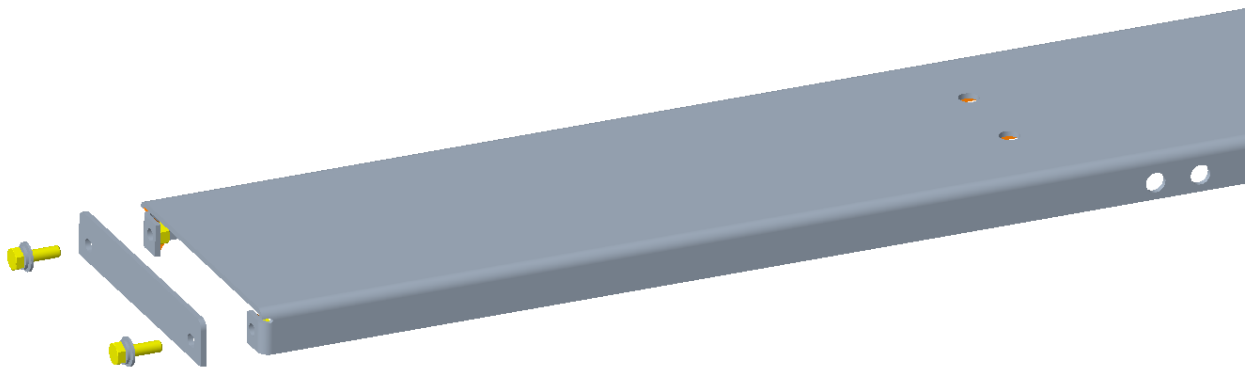

Fig A

- 3) On the top of the broom frame, align attachment brackets with the corresponding holes. The short legs of the L-shaped brackets face the outside of the broom frame! The angled section of the brackets faces the front of the tool (the front of the broom frame DOES NOT have any holes drilled into its lip). Attach both brackets by threading a 3/8-16 bolt through a lockwasher, flat washer, the bracket, broom frame into a nut welded onto the back side of the broom frame. Tighten with a socket and wrench once all hardware has been threaded. [fig. B]
- 4) On the top of the broom frame, align the Toplink brackets with the corresponding holes. The short legs of the L-shaped brackets face the outside of the broom frame! The angled section of the brackets faces the front of the tool (the front of the broom frame DOES NOT have any holes drilled into its lip). Attach both brackets by threading a 3/8-16 bolt through a lockwasher, flat washer, the bracket, broom frame into a nut welded onto the back side of the broom frame. Tighten with a socket and wrench once all hardware has been threaded. [fig. B]

- 5) Slide Toplink in between the two Toplink brackets. Thread the 5/8-11 bolt through a washer, 1st bracket, Toplink, 2nd bracket and washer then thread on 5/8-11 nut. Tighten with a wrench and socket or two wrenches. [fig. B]

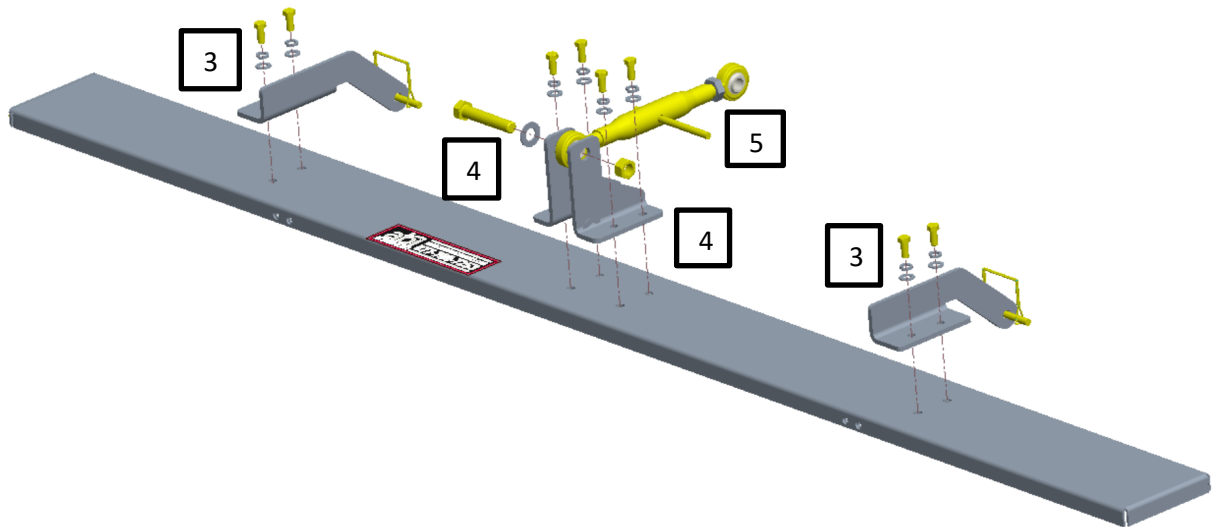

Fig B

- 6) Flip broom frame over so the bristle channels are facing up. Carefully insert each bristle piece into each channel. The fit is intentionally snug. OPTIONAL: gently tap each bristle piece with a rubber mallet to fully secure. [fig. C]
DO NOT pound bristles in with your hand. The metal bristle cap may cut you!

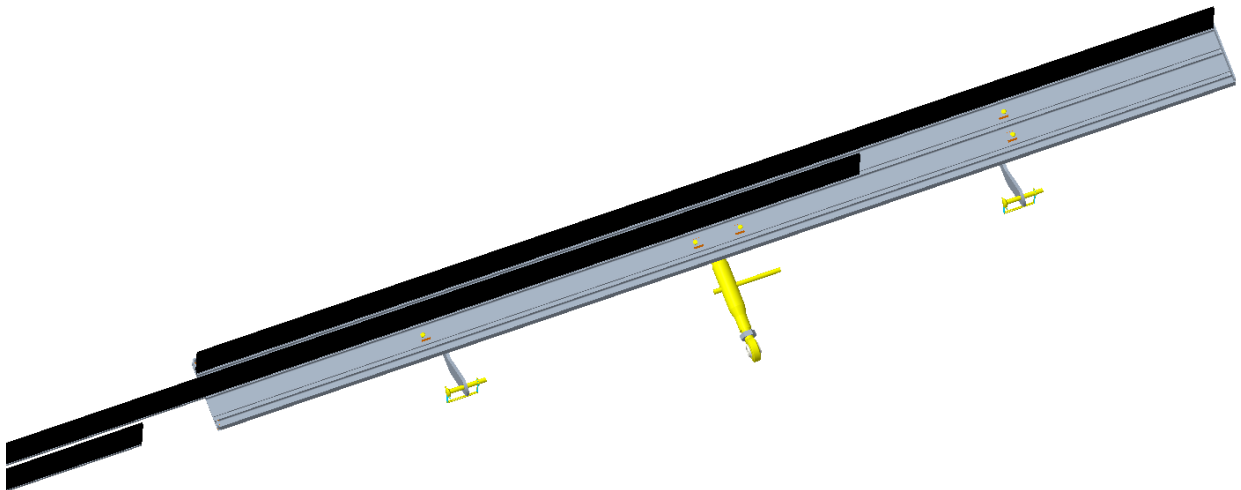

Fig C

- 7) Once all bristle pieces are fully inserted, replace the broom frame end cap with the hardware it was originally attached with. Tighten carefully, and make sure the cap fits flush to the end. [fig. D]

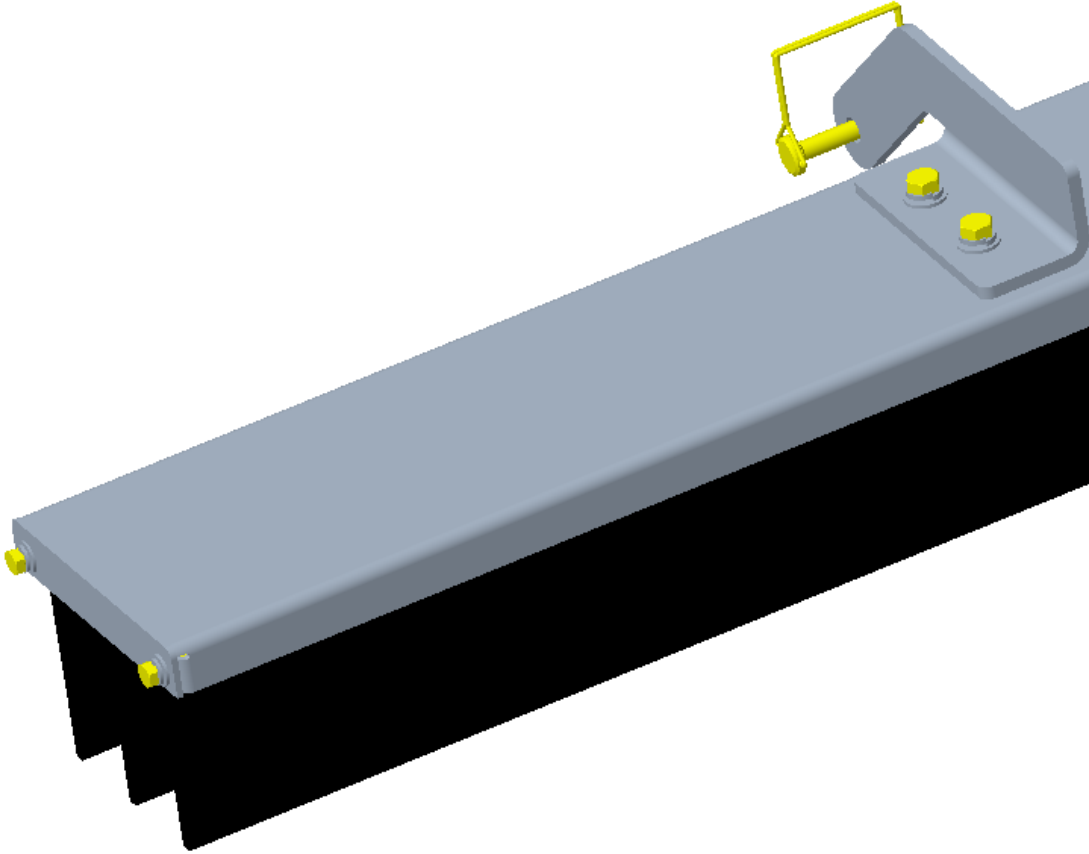

Fig D

***Congratulations! Your ABI® Fine Finish Broom is ready to use on your ABI® product!
Remember to refer to your tool's documentation for proper use and safety guidelines!***